



Tech Master GPM4020 Series

4.5 Purity Two Stage Brass Barstock Diaphragm Manual Change Gas Control Panel (BS EN ISO 7291)



The Tech Master GPM4020 Series two stage, single cylinder manual change control panels are designed for primary pressure gas control of non-corrosive or toxic, technical gases up to grade 4.5 purity (99.995%), on gas distribution systems where constant delivery pressure is required.

- **GPM4021** Series | Two Stage Single Cylinder Diaphragm Manual Gas Change Control Panel, FKM Seal, FKM Pressure Relief Valve
- **GPM4022** Series | Two Stage Single Cylinder Diaphragm Manual Gas Change Control Panel, EPDM Seal, EPDM Pressure Relief Valve

★ FEATURES

- High pressure isolation valves
- Two stage pressure regulation
- Process line isolation valve
- Encapsulated valve design
- Single cylinder configuration

🔧 MATERIAL

■ Body	Brass Barstock
■ Bonnet	High Strength Alloy
■ Diaphragm	Polychloroprene (Neoprene®) (CR)
■ Valve Seat	Polyamide (Nylon®)
■ Seal Option	FKM / EPDM
■ Filter	10 Micron 316L Stainless Steel

👍 SPECIFICATION

■ Maximum Inlet Pressure	15 bar (220 PSI) 60 bar (870 PSI) 300 bar (4350 PSI) *
■ Delivery Pressure Range	3.5 bar (50 PSI) 6 bar (90 PSI) 10 bar (150 PSI)
■ Gauges	50mm (2") Diameter
■ Ports	1/4" NPT Inlet
■ Temperature Range	-20° C to +60° C (-4° F to +140° F)
■ Flow Coefficient (Cv)	0.078
■ Weight	4.25 kg (9.4 lbs) ****

* Subject to Cylinder Connection **** Subject to final configuration

✓ FLOW PERFORMANCE

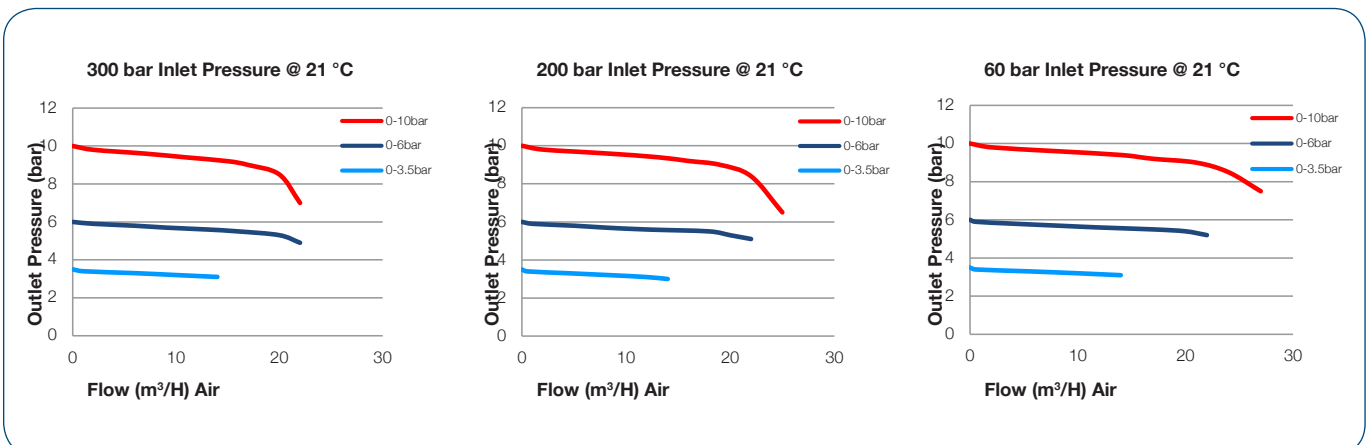

DRAWINGS

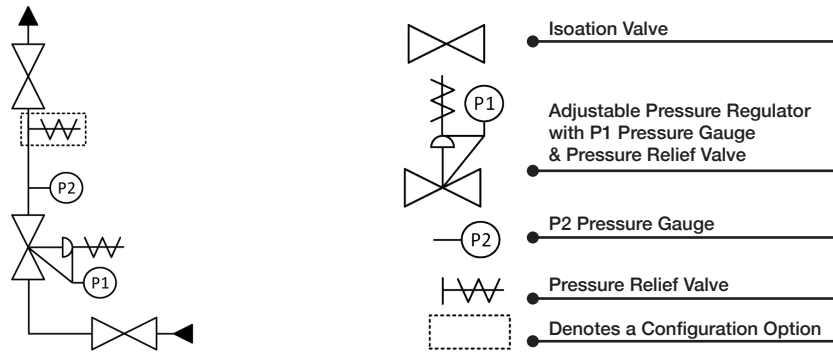
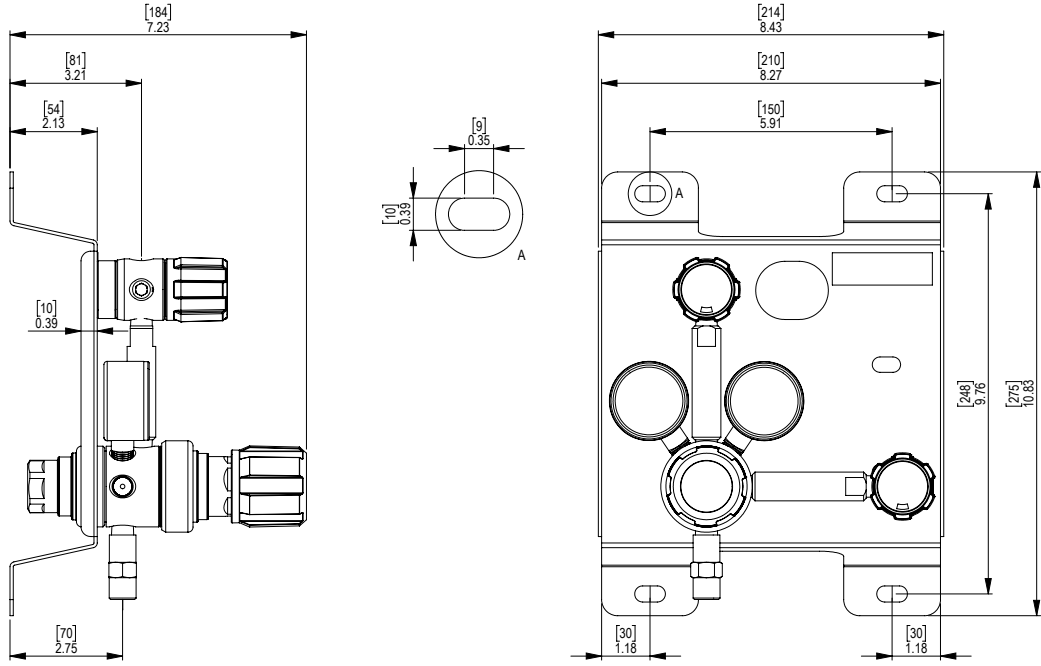

MODEL NO. SELECTOR GUIDE

Example for a Model No. for GPM4020 Series

Product Type	Inlet Pressure Bar [PSI]	Outlet Pressure Bar [PSI]	Inlet Pressure Gauge	Outlet Pressure Gauge	Inlet/Cylinder Connection	Outlet Connection	Options
GPM4021-	02 60 [870]	03 0 to 3.5 [50]	00 No Gauge Fitted	00 No Gauge Fitted	000 1/4 NPT Female	00 1/4 NPT Female	A No Options Selected
GPM4022	04 300 [4350]	04 0 to 6 [90]	01 bar/PSI	01 bar/PSI	001 1/8 Stainless Steel Compression	01 1/8 Stainless Steel Compression	F Bonnet Vent Capture Kit
	06 15 [220]	05 0 to 10 [150]	02 bar/PSI Contact Gauge		002 1/4 Stainless Steel Compression	02 1/4 Stainless Steel Compression	M CO2 Burst Disc
					003 6mm Stainless Steel Compression	03 6mm Stainless Steel Compression	P Calibration/ Pressure Test Certificate
					004 1/4 NPT Male	04 1/4 NPT Male	R Fitted Pipeline Pressure Relief Valve, FKM Seal
					007 G3/8 BSP R/H Brass Male	06 G1/2 BSP R/H Brass Male	S Fitted Pipeline Pressure Relief Valve, EPDM Seal
					008 G3/8 BSP L/H Brass Male	07 G3/8 BSP R/H Brass Male	T Fitted High Pressure Purge Facility, FKM Seal
						08 G3/8 BSP L/H Brass Male	U Fitted High Pressure Purge Facility, EPDM Seal
							X Special Instruction